

012000/169
UNCLASSIFIED

Australian Army History Unit
16 July 2014



ARMY JOURNAL

No. 258 NOVEMBER 1970

ARMY JOURNAL

Editor: C. F. Coady

Staff Artist: D. E. Hammond

Printed and published for the Australian Army by The Ruskin Press Pty. Ltd., and issued through Base Ordnance Depots on the scale of one per officer, officer of cadets, and cadet under officers.

Contributions, which should be addressed to the Editor, Army Journal, Directorate of Military Training, Army Headquarters Canberra, A.C.T. 2600, are invited from all ranks of the Army, Cadet Corps and Reserve of Officers.

\$10 will be paid to the author of the best article published in each issue. In addition, annual prizes of \$60 and \$20 respectively will be awarded to the authors gaining first and second places in the year.

The information given in this Journal is not to be communicated either directly or indirectly to the Press or to any person not authorized to receive it.

COVER: 'Supply Dropping, Freddie Beach, Bougainville, 1945', by war artist H. F. Abbott. At the Australian War Memorial.

ARMY JOURNAL

A periodical review of military literature

No. 258, NOVEMBER 1970

Contents

- 3 Soldier-Tradesmen
Major A. Weaver
- 11 A Plea from the Audience
Major B. J. O'Neill
- 16 AMF Gold Medal and ASCO Prize Essay Competition — 1970
- 18 Thrice Your Servant
Lieutenant Colonel A. Argent
- 30 Education or Training: Is That The Question ?
Captain A. Sandery
- 40 The Sioux Wars, 1854-91
Staff Cadet C. D. Clark
- 54 Book Reviews: *The Fourth Dimension of Warfare, Volume One
Thracian Peltasts and their Influence on Greek
Warfare*

CROWN COPYRIGHT RESERVED.

No article in this Journal is to be reproduced in whole or in part.

The views expressed in the articles are the authors' own
and do not necessarily represent General Staff opinion or policy.



(Australian War Memorial)

Men of the 2/24th Australian Infantry Battalion accompanied by scouts of the Papuan Infantry Battalion setting out on patrol in the Sattelberg area, 15 November 1943.

Soldier-Tradesmen

Major A. Weaver
Royal Australian Infantry



**The armourers, accomplishing the Knights,
with busy hammers closing rivets up,
Give dreadful note of preparation . . .**

—Shakespeare, Henry V, Act IV

The Requirement

SINCE the earliest days in history armies have had to rely on experts to attend to the maintenance, repair and modification of their weapons, armour, fortifications and means of transportation. The age of technological warfare makes particular demands on a wide field of technical experts. It is thus of utmost importance to have well-trained men who can be readily deployed to maintain the Army's striking power and mobility. The Australian Army, after the end of World War II, was vitally concerned with these requirements. To ensure that adequate provisions for the training of soldier-tradesmen was assured for the future the problem was given close attention.

The Army Apprentices School

To meet the challenge, on 2 August 1948 the first intake of 63 apprentices arrived in Balcombe, Victoria, from all states of Australia. Thus the Army Apprentices School, based on British Army pattern, embarked upon its role of training soldier-tradesmen. Since then 2,337 soldier-tradesmen have graduated. The annual intake has risen to 180 apprentices. Eligibility for entry into the school requires candidates to have reached the age of fifteen and be under the age of seventeen on enlistment. Applicants must have passed in English, mathematics or

Major Weaver, who has contributed previously to the Army Journal, is the commander of the Battalion of Apprentices and supervisor of regimental training at the Apprentices School.

arithmetic and at least two other subjects at the equivalent of Fourth Year of Secondary Schooling in Victoria. They must have an above average intelligence rating. Candidates are obliged to enlist in the ARA for a period of nine years, which includes service at the Army Apprentices School and in practical training with their respective corps. Finally, the graduate is posted to a unit on the order of battle of the Australian Regular Army.

The Setting

Balcombe is situated near the seaside resort of Mount Martha on Port Phillip Bay. The school occupies the camp sites which were used by the United States Marine Corps during World War II. It still occupies hutted accommodation. Plans for completely new brick barracks with provision for 850 apprentices are being considered.

The Aim

The aim of the Army Apprentices School is to train boys to become soldier-tradesmen for service in the Regular Army. The mental and moral qualities are fostered, which are essential in a good soldier and citizen, and which provide fitness for higher rank. Towards realizing the aim, the curriculum is designed to provide educational, military, physical and technical training. All this to fit apprentices for service as highly skilled soldier-tradesmen.

Scope of Instruction

The Army Apprentices School curriculum is designed to provide highly skilled soldier-tradesmen for the Army in the trades of: fitters and turners, vehicle mechanics, carpenters and joiners, plumbers and pipefitters, bricklayers, electrical mechanics, electrical fitters, radio mechanics and other trades as may be determined by AHQ.

Subsequently, on graduation, soldier-tradesmen have the opportunity to further their technical training. Some become armourers and artificers, others specialize in electronics and radio mechanical spheres.

Apprentice Musicians

Apprentice musicians attend a two-year course of instruction at the School of Music at Balcombe. They receive military training and

are administered by the Army Apprentices School. They provide a most effective Drum Corps for the Battalion of Apprentices and are utilized as such on many occasions.

The Soldier-Tradesmen at Regimental Training

Like all specialists in the Army, the apprentice is made aware from the outset that he will always be a soldier first and only then a specialist. He is taught his trade-skills to further the military aim. Apprentices are given instruction on all aspects of the all-arms recruit training syllabus as taught by recruit training establishments. The



The Army Apprentices School Parade for the Presentation of the Governor General's Banner, 30 August 1969.

regimental training cycle is superimposed on the apprentices trade curriculum in the time they are at Balcombe. Additionally, suitable apprentices are given instruction to qualify them for promotion to corporal in subjects A and C. A selected number of apprentices are trained as drivers in addition to their trade training. Apprentices are made aware that as soldier-tradesmen they will eventually have to be prepared to bear arms. They are made aware of their likely employment in a theatre of military operations: this may involve protection of their bases. It may place them in a situation in which they, in their specialists role, could act as members of special task squads on offensive operations,

or destructive tasks against enemy installations, demolition or reconnaissance duties.

Soldier-tradesmen may well have to meet the ever increasing requirement for civic action tasks which could involve Australian troops in South-East Asia.

Trade Training

The trade training is given to apprentices by an integrated military and civilian instructional staff organised into wings. These wings are concerned with metal trades, building trades, electrical trades, motor vehicle training and drawing instruction. The school is fully equipped with the necessary workshops and classrooms to facilitate such instruction. Instruction is co-ordinated by a military Supervisor of Technical Training in conformity with the policies of the Victorian Apprenticeship Commission and the Victorian Education Department. Successful apprentices qualify as soldier-tradesmen after their four years of training. They spend a final period under Apprentice Masters in units of the Royal Australian Engineers, Royal Australian Corps of Signals, and the Royal Corps of Australian Electrical and Mechanical Engineers. The qualifications thus gained by the soldier-tradesmen are recognized by the apprentice commissions in all Australian states.

Educational Training

The General Education Wing of the school is staffed by officers of the Royal Australian Army Educational Corps. The wing has the task of preparing apprentices for qualifications up to Leaving Technical Certificate standard. Trade mathematics, trade science and Army First Class Certificate subjects in mathematics and English are taught to all apprentices.

Such instruction is mandatory for the successful completion of trade training. Apprentices who have the necessary qualifications and incentives are given instruction to matriculation level.

Physical Training

Physical training instruction under a qualified physical training officer and his staff is provided for as part of the weekly syllabus. Apprentices are also given instruction and guidance in all aspects of various sporting activities.

Character Training

Chaplains for every denominational group are attached to the school and conduct a tutorial programme of instruction on a weekly basis as part of the training syllabus.

The Battalion of Apprentices

The overall command of the school is exercised by a lieutenant-colonel. In order to give apprentices the best control and guidance, apprentices are grouped into four Apprentice Companies, which make up the Battalion of Apprentices, commanded by a major, the Supervisor of Military Training. All apprentices who are in their first year of training are grouped in a company. This enables the military staff to devote their particular attention to the newcomer who requires considerable guidance and man-management during his settling-in period. The remaining companies consist of apprentices in the later years of training.

An instructional staff of one CSM per company and one sergeant and one corporal per platoon has been allotted. This staff is organized into military training wings, specializing in drill, weapon training and field training. Great care is taken to select only the most suitable NCOs for posting to the school, as apprentices — owing to their age — require a special type of treatment. The school thus has to assume heavy responsibilities for apprentices beyond those normally encountered in military units, where members are adults.

The Training Cycle

At present, the training cycle over the three years the apprentices spend at the school is organized in such a manner as to have a balanced distribution of all subjects each week on the following basis:

• Trade Training	23%	of total periods
• General Trade Practices	27%	„
• Education	25%	„
• Military Training	11%	„
• Sport	6%	„
• Physical Training	4%	„
• Religion	2%	„
• Administration	2%	„

Recreation

The school offers the apprentice a diversity of recreational facilities. These include sailing, fishing, chess, hobbies, cinema screenings, a well-stocked library, dancing classes, bush-walking, radio clubs, weight-lifting, and apprentices' club and canteen facilities.

Discipline

The apprentices are subject to the same military code of discipline as the rest of the Army. The youth of the apprentices and their low pay, however, seems to call for a detailed reappraisal of such a system.

In order to provide some additional measure of man-management and discipline and to promote leadership qualities, a battalion sergeant-major, an RQMS and apprentice sergeant-majors for the companies, as well as apprentice sergeants and corporals have been appointed as local, acting, unpaid ranks.

Sport

Sport plays a most important part in the apprentice's life. Apprentices participate in all winter and summer sports. They are predominant throughout Melbourne and Victoria in the leagues of which they are an integral part. The annual inter-service sports contests against RAN and RAAF apprentices are bitterly contested events. The *esprit-de-corps* of the battalion is displayed with verve and spirit on such occasions.

Ceremonial

The Apprentice Battalion features prominently on many ceremonial occasions in Victoria throughout the year. The citizens of Mornington have taken the boys to their hearts and consider them as an integral part of their community. Consequently, in August 1969 the Apprentice Battalion was granted the Freedom of the Town of Mornington. This was celebrated with apprentices conducting the parade without any ARA staff participation. In fact it has become the accepted form to conduct ceremonial parades exclusively under the command of the Apprentice Battalion Sergeant-Major. The Apprentice Battalion's Regimental March consists of a melody of 'Advance Australia Fair', 'The US

Marine Corps Hymn' and 'Waltzing Matilda'. The US Marines who occupied Balcombe Camp during World War II are thus honoured.

The complexity of the school poses occasional problems. Thus various trade wings of the school, the three age groups of the apprentices, the educational problems and the peculiarities of the integration of civilian and military staffs, offer some complications. The requirement



His Excellency the Governor of Victoria and the GOC Southern Command reviewing apprentices at the official opening of the 113th Royal Melbourne Show.

for military training, physical training, religious instruction, sport and recreation are additional factors. Continuous changes have been made to meet these problems and to adopt whatever courses were advisable from time to time.

Conclusion

The foresight shown before 1948 when it was decided to train soldier-tradesmen has yielded great dividends in skilled manpower and leadership material for the Army.

The Army Apprentices School is now well established with a proud tradition of over twenty-one years service. It has attained the potential for further expansion to satisfy the increasing needs of our growing modern Army in the provision of soldier-tradesmen.

The young men who have graduated as soldier-tradesmen have established themselves as competent and indispensable. They are not only a valuable asset to the Army as specialists; they are capable soldiers and leaders who contribute generously to the efficiency of our modern Army. □

FLANDERS, NOVEMBER 1914

Upright in a clean suit of service dress and breeches, his boots polished, a cavalryman carrying immediately behind a lance with his personal pennant fluttering below the point, Haig's face we are told by a dozen eyewitnesses remained calm. About noon he had trotted forward with some of his staff in just this way, observing without comment or apparent emotion the ragged figures of the stragglers, the painful flow of the wounded, the guns and howitzers tugged back with empty traces among the teams of horses. When the report came through that Gheluvelt had been re-entered, he showed no joy, no elation. He was a dour man. Yet of all the commanders available in the *British Expeditionary Force* at that time he was probably the officer most suited — perhaps the only one — to direct operations in front of Ypres. At times small-minded, given to criticizing faults in others of which he was himself guilty, he had none the less a high sense of duty, a cool head and a degree of comprehension and instinctive skill in higher tactics. Though he knew less as a cavalry man about the practical capabilities of the infantry than Smith-Dorrien, an infantry officer, he knew more than Rawlinson who, despite his infantry background, had never commanded anything in a regiment above a platoon. Haig had never shunned regimental service. He lacked Allenby's power as a commander and his boldness; but he was more calculating. He had now to calculate the extent to which he could hold the present corps line. There was an immense temptation to fall back. Haig had told his chief engineer to select a defensible line in rear towards Ypres but he knew that whilst this might appear to offer a relief for his weary soldiers, they would find it difficult to break cleanly from the Germans at all points; and they would in any case be pursued quickly to a line in which, as yet, there was not a single trench dug.

—Anthony Farrar Hockley, *Death of an Army* (London 1967.)

A Plea from the Audience

Major B. J. O'Neill

Royal Australian Artillery

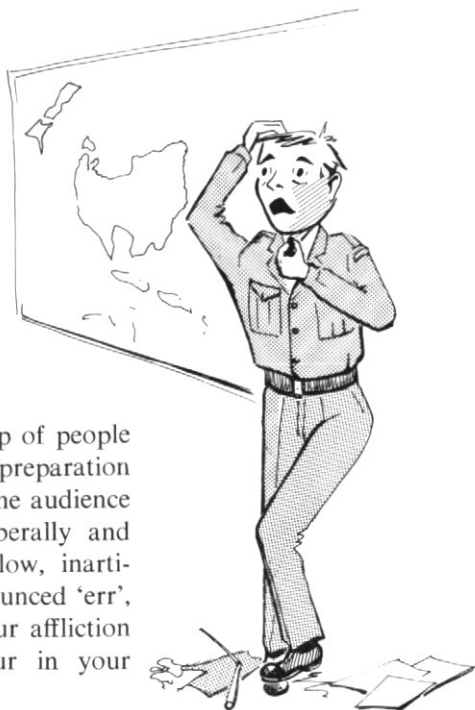

ARE you one of the unhappy group of people who, despite hours spent in careful preparation of a speech, persistently deliver to the audience a series of disjointed sentences liberally and annoyingly interspersed with that low, inarticulate vocal sound sometimes pronounced 'err', but more often as 'arrh'? Or is your affliction even worse; does the 'arrh' occur in your normal conversation as well?

If you can honestly answer no to this challenge, then your attention may be more rewardingly diverted to some other article in this volume. But before you depart, are you absolutely certain of your innocence? Check yourself out with a tape recorder or present yourself to a trustworthy and critical listener. Perhaps your past audiences have been too kind to comment, too anxious to save you embarrassment at the expense of their own discomfort. Think back on how often you, as a listener, have been almost driven to distraction by some other speaker's impediment.

On the other hand, if you are prepared to admit to suffering this extremely common social disease of the vocal chords then this article is intended for you. Similarly, if you feel embarrassment at the frequent display of its symptoms, either by yourself or by others, then this article could be of value.

Major O'Neill graduated from OCS in 1954 and was allotted to RAA. He served with 12 NS Trg Bn before training as an AOP pilot in 1956. Following regimental postings in artillery and aviation units, and a tour of duty as an aide-de-camp, he received overseas training as a flying instructor and served as such with 16 Army Lt Ac Sqn and the RAAF. After two years as a staff officer in HQ RAA 3 Div, he attended Staff College, Queenscliff in 1969 when this article was written. He is at present 2IC of 8 Medium Regiment RAA located at Holsworthy, NSW.

Still reading? Good, for by this admission of your affliction, or wish to help others less fortunate than yourself, you have possibly taken the first important step towards its complete eradication. All that remains to be done now is to determine the reason for the use of this indefinable vocal sound, suggest a cure, and then conscientiously adopt a deliberate course to achieve its complete extinction from the vocabulary.

Perhaps the most difficult of the above tasks is the tracing of the cause of the problem. It would be all too easy to accept what is probably the obvious answer and place the entire blame upon nervousness. But this does not appear to be the complete answer. Even from the mouths of the most poised and confident speakers the critical listener is likely to have his ears offended by this troublesome 'arrh'.

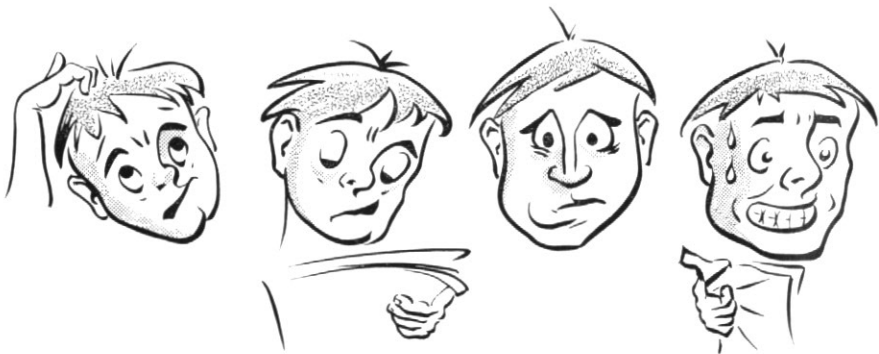

Detailed examination is likely to reveal a variety of causes. Undoubtedly nervousness is the more prevalent, but others, some less obvious and others less flattering, are worthy of mention. Although not complete, the list includes: lack of confidence in one's vocabulary; lack of concentration on the subject matter leading to mental and verbal confusion; lack of synchronization of speech and thought processes; faulty breathing technique leading to lack of rhythm; and several others best left to medical or psychiatric practitioners for diagnosis and subsequent treatment.

At this point one must disregard the statement that any man who is his own doctor has a fool for a patient, for you are yourself in the best position to choose from the above list the cause of your problem. You, the patient, must determine whether the continuing

abuse of your audience is due to faulty technique, careless preparation or unjustified fear.

Now, let us assume that you have identified yourself with one or more of the above-mentioned causes. The next important step is to find the cure suitable to your particular problem.

First, we shall examine the more common problem of nervousness. This is usually the manifestation of fear or an 'anxiety state'. There are some interesting theories of nervousness, perhaps the most applicable being that attributed to Charles Darwin. This is known as the 'Theory of Escape'. Darwin claims that faced with a new situation the beginner wants to run away; fear predominates when escape is cut off and the symptoms of nervousness appear. It follows then that even for the practised speaker each audience is a new experience, pregnant with uncertainty; so he too is nervous. The manifestation may take different forms. In the extreme case it may lead to a complete mental blockage more commonly known as stage or mike-fright. In most cases, however, it asserts itself in either a physical form such as foot-shuffling or unnatural gestures, or in a verbal form such as a stammer or, our particular enemy — the 'arrh'.

Nervousness is not easily eliminated. In fact some notable writers assert that it is an essential part of the equipment of the competent speaker. What must be done to lessen its impact however is to recognize it as such and to come to grips with it in order to reduce and control its public manifestations.

The time honoured cure for this problem of nervousness is more easily stated than applied: it is relaxation. Various authorities on voice production suggest differing approaches towards its attainment, ranging from properly applied breathing to concentrating on mental pictures to be conveyed to the audience.

If this was your diagnosis then you are on the way to resolving your problem, for a great part of the cure lies in its recognition. For the remainder of the cure it is suggested that you seek access to one of the many valuable textbooks dealing with voice production. Armed with the habits of good speech — acquired during practise — your nervous system will automatically adjust itself; the relaxing mechanisms will come forth; fear will be mastered and the 'arrh' will disappear.

Now let us examine some of the other sources from which the 'arrh' emerges. Of those previously listed, two may be considered together — lack of concentration and lack of synchronization of

thought and word. There is a major factor common to both of these in that they usually result from lack of preparation.

The good speaker will always devote ample time to research on his subject matter; he will at least have made notes of a sequence of inter-dependent ideas, or headings. In fact he may well have committed his every intended word to paper. He will have studied and absorbed his thoughts and words and will most certainly have rehearsed his speech, either in front of a mirror or into a tape recorder.

When he stands in front of his audience he will reap the rewards of his diligence. His memory process will flow evenly, with each phrase suggesting the next, and his words will be in sequence with his thoughts. He will not suffer the involuntary pregnant pause which accompanies the mental search for the next word, and invites distraction and the insertion of the conveniently time-killing 'arrh'. Speech is a habit which is developed along the right lines simply by repetition of good habits; and adequate preparation of what is to be said is perhaps the best of these habits.

Another source mentioned was the limited vocabulary. This may leave the speaker's voice suspended in mid-sentence whilst his memory cells feverishly search for the word suitable to the occasion. Hard work again provides the solution to this problem. Extensive reading of books above the standard of the soft-covered Western will undoubtedly build up the vocabulary over a period. Others find attention to crossword puzzles of value in this regard, whilst the really earnest speaker will make a deliberate study of a dictionary, learning a couple of new words each day and applying them, in context, to everyday conversation.

The remaining problem area to be examined is that of faulty breathing technique. Good breathing technique is as essential to the speaker as it is to the singer, for it will lead to the real secret of voice control — thinking and talking in phrases. It imparts a rhythm which helps the speaker to think on his feet and the audience to listen more easily and attentively. This rhythm will dispel the opportunity for the vocal chords to emit the troublesome 'arrh'.

Remedial action for the faulty breathing technique is relatively simple. The cure lies in selecting a suitable passage of prose — perhaps one of your previous speeches — and placing pause marks at suitable intervals throughout. The placing of these marks will vary between individuals, especially the breath pauses, and they will not

necessarily be given the same length. Once the habit of these rhythm phrases forms, better articulation and voice control can be practised during ordinary speech.

Well, are you prepared to accept the challenge? The above suggestions have been offered with but one objective in mind — to diminish the occurrence of the 'arrh'. This objective can only be achieved if you, the afflicted, are prepared to make the necessary effort to improve the world of the listener.

Let us relegate the 'arrh' to the only place where it serves any useful purpose — in the doctor's surgery. □

ANNUAL AWARDS

The Board of Review has awarded the annual prize of \$60 for the best original contribution published in the *Army Journal* during the year ended June 1970 to Major J. Fletcher's 'Intelligence: A Principle of War' (December issue).

The second prize of \$20 has been awarded to Baron Geyr von Schweppenburg for his 'Military Review and Appreciation of the Year 1968' (August issue).

AMF Gold Medal and ASCO Prize Essay Competition 1970



1. Entries for the AMF Gold Medal and ASCO Prize Essay—1970 close with the Secretary to the Military Board on 31 Mar 71.

Eligibility

2. All ranks of the active and reserve lists of the Australian Military Forces are eligible to compete.

Aim

3. The aim of this essay competition is to encourage original thought and good writing on a military topic of general interest to the Army.

Subject

4. Competitors may select their own subject. As essays may be published in the *Australian Army Journal* or similar unclassified publications they are not to contain classified material. Essays must be written solely for the competition.

Sections

5. There are two sections:
- Senior—for officers
 - Junior—for other ranks

Prizes

6. Prizes may be awarded as follows:
 - a. For best essay overall—AMF Gold Medal and \$100.00.
 - b. For best essay in each section (other than best overall) \$50.00 each.
 - c. The referees are empowered to recommend that the Medal and Prize not be awarded if, in their opinion, no essay submitted is of a sufficiently high standard.
 - d. A prize of less than \$50 may be awarded to the winning essay in either section if, in the opinion of the referees, the standard of the essay does not warrant the award of the full amount. In the case of two or more essays of equal merit from the same section, the prize money for the section may be shared.

Judging

7. Essays will be judged by at least three referees appointed by AHQ.
8. The decision of the referees will be final.

Submission of Essays

9. Essays are to be typewritten and submitted in quadruplicate. Units are to provide typing assistance where so requested.
10. Length of essays is to be between 3,000 and 5,000 words.
11. Authorship is to be anonymous. Each competitor is to adopt a pen name and enclose with his essay a sealed envelope with the pen name and section identification typewritten on the outside and his name and unit address inside.
12. The title and page number of any published or unpublished work to which reference is made in the essay must be quoted.
13. Essays are to be addressed to the Secretary to the Military Board Army Headquarters, Canberra, A.C.T., 2600. The envelope is to be marked 'AMF Gold Medal and ASCO Prize Essay'.

Promulgation of Results

14. The results of the competition will be promulgated in AAOs and in a Notice to AROs for display on unit boards.

Thrice Your Servant

The Chinook

*Lieutenant Colonel A. Argent
Australian Army Aviation Corps*



I have no strength in measure, yet a reasonable measure in strength.

—Henry V.

THINK of Vietnam and moving guns, men, supplies, refugees, pigs and rice and aircraft recovery and one thinks of the CH-47, the Chinook. This article deals with some of the features of this versatile aircraft, particularly its latest model, the CH-47C, the selection of which for the Australian Services was announced by the Minister for Defence, Mr Fraser on 19 August.

Development

In the family of Army aircraft the Chinook is a medium helicopter, with a minimum three-man crew (two pilots, flight engineer) and it is a development of the Vertol Company's tandem rotor machines that go back to 1948—to the HRP-1 for example and the XH-16 of the early 1950s.

Over the years these aircraft grew from a payload figure of a 1,000 pounds for 100 nautical miles radius, through the successful CH-21 of the mid-1950s (the banana-shaped helicopter, 4,000 pounds for 100 nautical miles radius that saw service in Vietnam), to the prototype Chinook which first flew in 1961. Also, during the early 1960s, Boeing took over Vertol and the aircraft are now made by the Boeing Company, Vertol Division.

The first Chinook — in those days called the HC-1B — was delivered to the US Army in July 1962. Since then over 500 Chinooks have been bought by the US Army. The latest model, the CH-47C, sometimes called the 'Full Charlie' to distinguish it from the 'Charlie Minus' came into service in September 1969. Table 1 gives some

TABLE 1

Current Model Chinooks

	Engines	Shaft horsepower (1)					Fuel consumption at 75% normal power imp lb/GPH	Fuel capacity lb/imp gals	Weights (lb)		Typical planning figures (7)		
		Maximum (2)	Military (3)	Normal (4)	90% Normal	75% Normal			Basic (5)	Gross (6)	Cruise Speed (knots) (8)	Payload with full fuel	
												Maximum	Tropics
CH-47A	T55-L-7B	2,650	2,650	2,200	1,980	1,650	1365/176	4,036/518	17,900	33,000	120	10,300	8,000
CH-47B	T55-L-7C	2,850	2,850	2,500	2,250	1,875	1435/184	7,353/942	19,400	40,000	130	12,500	10,000
CH-47C	T55-L-11	3,750	3,750	3,300	2,970	2,475	2000/255	7,353/942	20,400	46,000	145	20,000(9)	20,000(9)

NOTES

- (1) These figures are for a standard day at sea level, i.e., 59°F, 29.92 inches of barometric pressure.
- (2) Maximum power — that which can be delivered for 10 minutes. In some cases even though this figure is the same as military power, an increase in performance is gained at maximum power by operating at higher engine temperatures for a shorter period.
- (3) Military power — maximum horsepower that can be delivered for 30 minutes.
- (4) Normal power — maximum power allowable for continuous operation under specified conditions.
- (5) Basic weight — empty (i.e., ex factory) weight of aircraft plus all appointments, integral equipment (e.g., armour plating) and trapped fuel and oil; but excludes passengers, cargo, crew, fuel, and oil.
- (6) Gross weight — Total weight of the aircraft allowed for take-off. It is the sum of basic weight, crew, personal equipment, passengers, cargo, special devices (e.g., stretchers, oxygen equipment, ferry tanks etc.) usable fuel and oil. This gross weight may be lowered, due to operating conditions, e.g., hot climate, high altitude landing zone and this will in turn affect the payload figures.
- (7) These figures will vary from theatre to theatre. Figures for particular areas will be set out in handbooks for the Chinook. See Employment and Utilization Handbook paragraph in this article.
- (8) Internal loads.
- (9) External load limited by capacity of the book.

details of current Chinooks. There are more A models, at the time of writing, than all others combined.

Engine and Transmission

The Chinook is powered by two Avco Lycoming gas turbine engines. In the CH-47C the engines are the T55-L-11, each capable of producing 3,750 shaft horsepower. The output from these engines goes to a combining transmission which is located at the forward section of the aft pylon. From this combining transmission a shaft drives the aft transmission (that turns the aft rotors) and another, much longer shaft drives the forward transmission (and from there the forward rotors). When viewed from above the forward rotor moves anti-clockwise, the aft rotor clockwise. The danger areas from the hot exhaust gases of engines under power are shown in Figure 1.

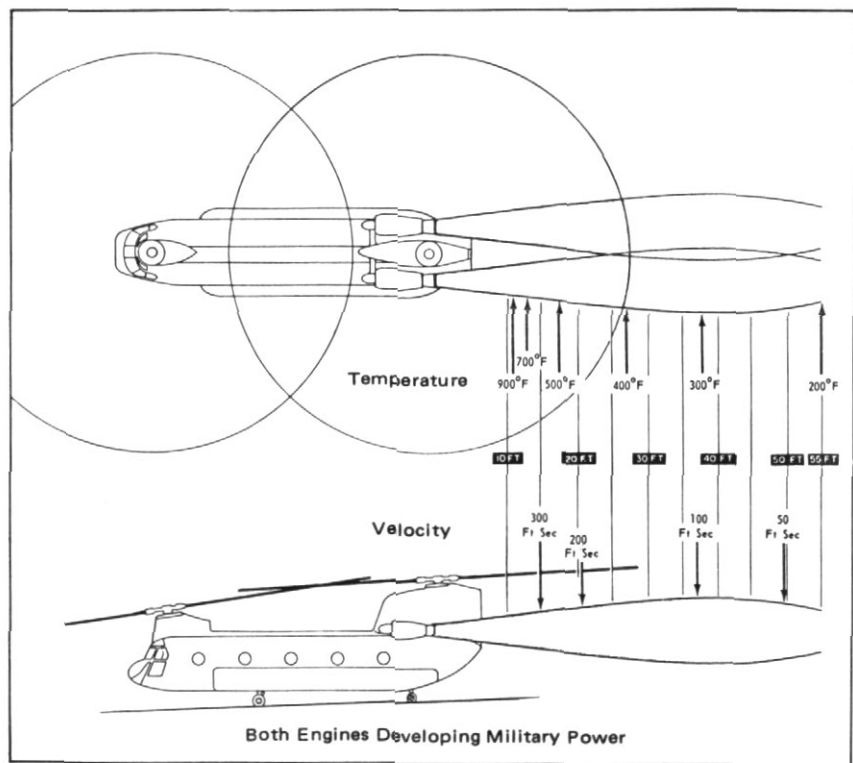

Figure 1. Danger areas from the Chinook's engines.

Engine Failure

Should an engine fail, both rotors continue to turn under power because the good engine is still driving through the combining transmission. Whether the aircraft will maintain altitude or not with one engine



(US Army)

A sling load into the Central Highlands of South Vietnam.

out will depend on a number of variables, for instance, the gross weight of the aircraft, the air temperature, the height of the aircraft above the ground, and whether it is hovering or in flight. However, in most conditions the Chinook will not only maintain altitude but have sufficient power in hand to climb, though it may be necessary to jettison cargo to do this. For example, a CH-47C on one T55-L-11 engine, at a gross weight of 36,000 lb¹, will maintain 2,000 feet above sea level on a hot day of 95°F (35°C) with one engine shut down. Instead of landing from a hover, with only one engine operating, for safety reasons a running landing is usually made.

¹ This figure is, in fact, conservative. On tests in a hot climate the CH-47C at 44,000 lb (which includes an external load of 20,000 lb), at 1,500 feet altitude, 70 knots airspeed, 230 rotor RPM, climbed at 700 feet per minute on one T55-L-11 engine.

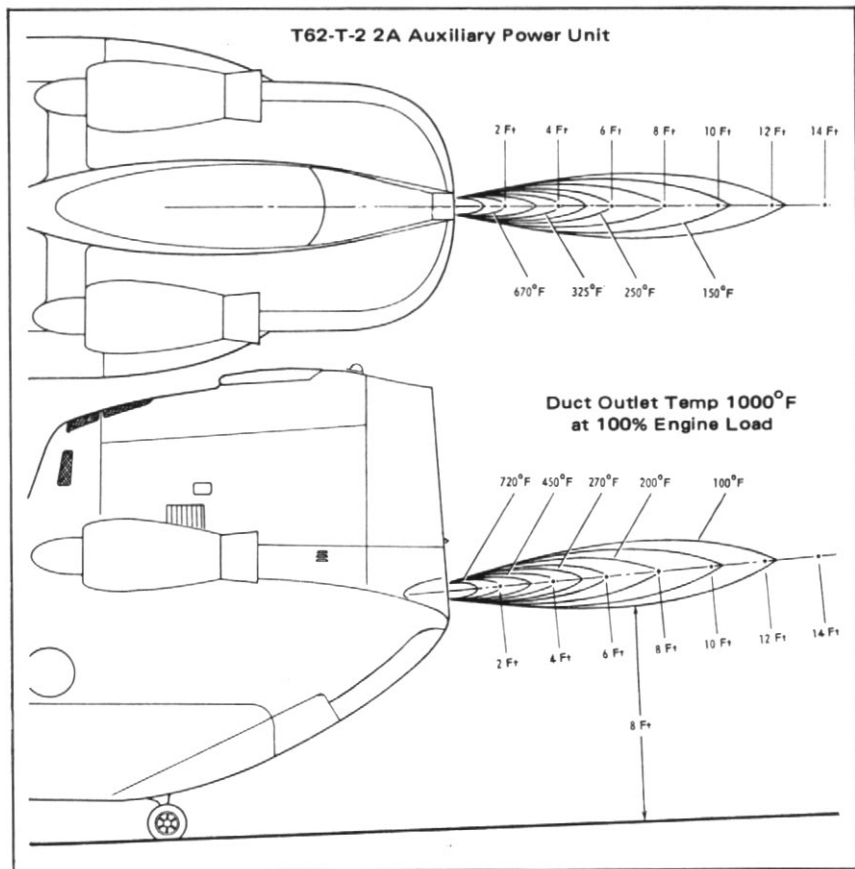

Figure 2. Danger area from the Chinook's auxiliary power unit.

Hydraulic Systems

Because of the weight of the rotor blades it is physically impossible for the pilot to alter their pitch (and so fly the aircraft) without some form of assistance. Therefore two, but separate, flight control hydraulic systems are installed. Hydraulics are so vital that the second system is there as a backup should the other fail. A utility hydraulic system, also separate from the two flight control systems, supplies hydraulic power to various components of the Chinook — to the engine starters, the ramp, wheel brakes, power steering (for use on the ground), cargo hook, the cargo/rescue winch. All three systems operate at a pressure of 3,000 pounds per square inch.

Auxiliary Power Unit

The weights of the rotors and their transmissions, the electrical systems and the requirement for field operations, amongst other things, makes direct starting by a battery such as in smaller aircraft, for example, the Iroquois, impossible in the Chinook. For these and other reasons an auxiliary power unit (APU) is fitted. The APU is a small, 66-horsepower gas turbine engine and is mounted above the ramp. The APU is started by the aircraft's 24-volt battery and hydraulic power from the utility system and once the APU is running with the flight control hydraulic pressures and electrical systems on line, the engines can then be started and the APU shut down. The danger areas from the hot exhaust gases of the APU are shown in Figure 2.

The Winch

The APU is used to provide the hydraulic power for the 3,000-pound capacity winch. The winch has 150 feet of $\frac{1}{4}$ inch cable and two reeling speeds are used — 20 feet per minute for cargo loading over the ramp, 100 feet per minute for hoisting. With pulley blocks, up to 12,000 pounds of cargo can be winched in at one time. The winch can be controlled from the cabin by the flight engineer or from the cockpit by the pilots. When the winch is in the hoist mode it is limited to 600 pounds and the cable is passed through the utility hatch — the hole in the floor of the cabin.

The Cargo Hook

The cargo hook is suspended beneath the centre of gravity of the Chinook — in the utility hatch. It can take 20,000 pounds though such an external load could be a rare event. Should the utility hydraulic system which operates the hook fail, the hook can be opened manually or pneumatically. The manual handle can only be operated by the flight engineer.

Electrical System

Alternating current is the primary source of power to operate the electrical and electronic equipment. 208V AC operates such things as some instruments, fuel pumps, vibration absorbers, the missile warm-up (originally the medium helicopter was designed to transport the Pershing missile); 115V AC more instruments, speed trims, stability

augmentation systems; 28V AC-instruments. The AC system after rectification provides 28V DC to operate components such as lights, boost controls, engine starting systems, engine trims (that is, turbine speeds) and radios. A 24V nickel cadmium battery supplies emergency DC power (e.g., for the FM radio) and power for auxiliary power unit starting. As there are two generators and two rectifiers, complete electrical failure is uncommon.

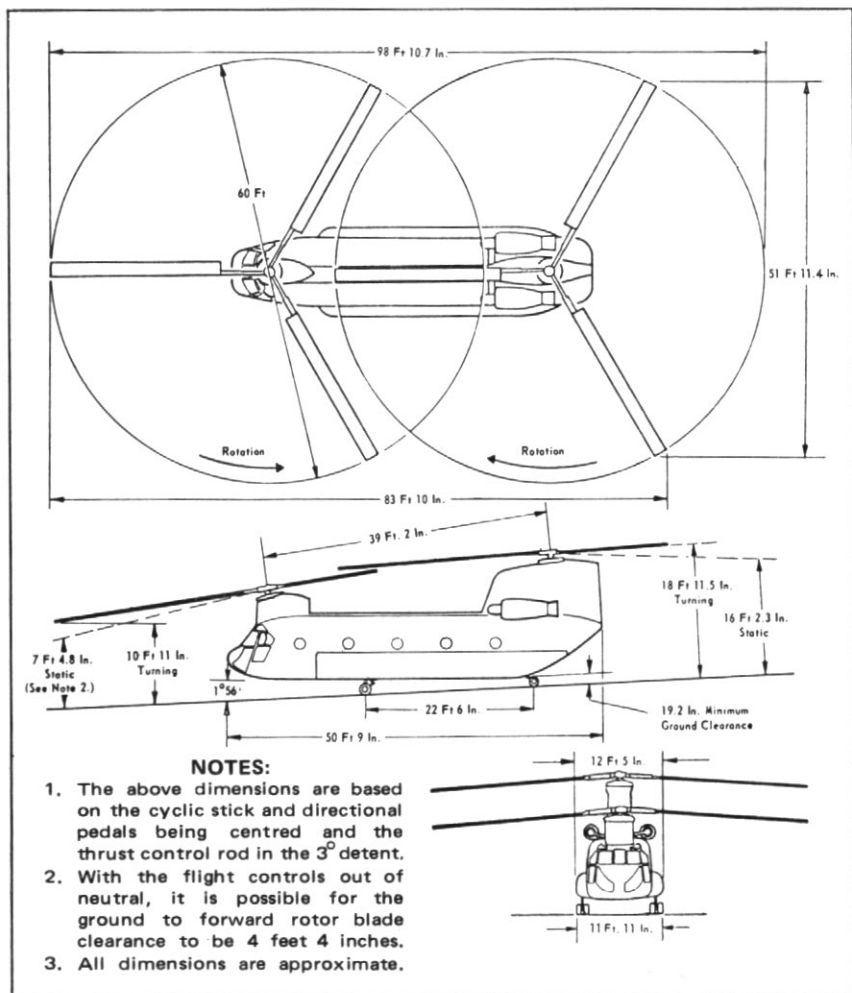

Figure 3. Overall dimensions of the Chinook.

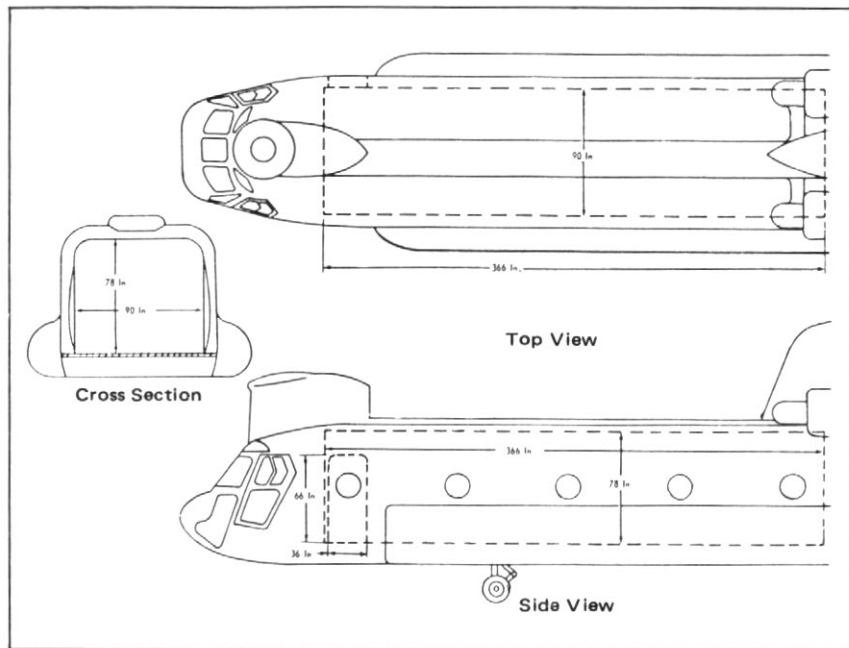

Figure 4. Chinook cargo compartment dimensions.

Dimensions

Figure 3 shows the overall dimensions of the CH-47C (note how close a forward rotor blade could get to a man's head) and Figure 4 gives cargo compartment measurements.

Flight Control Features

Some of the necessary features of the Chinook which add to its cost in terms of initial purchase price and maintenance manhours are:

Longitudinal cyclic speed trim. Simply stated, this is a device that tilts the rotors forward after the aircraft reaches a certain speed and thus the aircraft remains about level in cruise flight. Were this not installed the aircraft would either be restricted to slow flight or at faster speeds it would move through the air at a pronounced, nose down attitude which could over-stress the aft rotor system.

Stability augmentation system. Two are fitted. The system provides stability about the three axes of the helicopter. In the jargon of the trade it is usually pronounced 'SAS', rarely spelt.

Differential collective pitch speed trim. This system automatically positions the pilot's cyclic stick in relation to the forward speed of the Chinook.

Pitch stability augmentation system. This electrical and gyro system improves speed and pitch (i.e., nose up, nose down) stability.

Functioning of Basic Controls

As in other helicopters, the Chinook is controlled by changing the pitch of the blades collectively or individually. Both rotor discs tilt to the right for a right turn, to the left for a left turn. When the pilot moves the cyclic stick forward to move from, for example, a hover to forward flight, the pitch of the forward rotor blades decreases and



(US Army)

A soldier prepares to hookup a load of artillery ammunition. Stencils near the door gunner indicate that this Chinook has recovered seven aircraft.

simultaneously the pitch on the aft blades increases. The opposite action occurs when the stick is moved to the rear. This accounts for the nose low attitude that may be seen on take-off, the seemingly high nose attitude when approaching to a hover.

When the left directional pedal is pressed, the forward rotor disc tilts left, the aft right. This causes the helicopter to turn left. The opposite occurs when the right pedal is pressed. This is how the

Chinook is taxied with the forward wheels off the ground. Pedals are also required during certain phases of flight for directional control.

General Handling Characteristics

For 99 out of 100 hours the Chinook is a pleasant aircraft to fly either on instruments or in visual conditions, despite its relatively high noise level and, in some models, vibrations at certain speeds. That other one remaining hour is when things go wrong, and, of course, malfunctions don't only occur in Chinooks, but there are more things that can go wrong in them — hydraulic leaks for example. Pilots familiar with the approach speeds and attitudes of the Huey into a confined area may find the Chinook strange at first because of the different speed and the power that is available.

The aircraft is not pleasant for trooping, though mercifully the journey should not be a long one. The noise level seems to be higher than that of the C 130. Soldiers working for some time around Chinooks are advised to wear earplugs and hook men, of course, must wear goggles, earplugs and/or earmuffs.

Loads

When cargo is to be carried external loads are preferred for two main reasons: first, it is far quicker to hookup a sling load and release it on a spot than to go through the hot and tiring business of loading, tying down and unloading in the cargo compartment. The second reason is one of aircraft safety. Should the Chinook lose an engine, the cargo on the hook can be jettisoned and a safe altitude maintained. With a heavy internal load, the only way is down.

External loads are usually broken down into three major groups:

- Low density, for example, an empty corrugated water tank. Airspeed is limited with these loads because as airspeed is increased there is the danger that the load will stream aft and strike the underside of the fuselage.
- High density loads, for example, bags of cement. Usually cruise speeds — about 120 knots — can be maintained.
- Aerodynamic loads, for example, a recovered fixed wing aircraft. As such items tend to fly in the airstream, their aerodynamic properties must be destroyed. In a fixed wing aircraft this can be done by placing a plank on top of the wing. In addition a drogue chute with swivel fitting should be used.

Landing Zones (LZ)

Should a Chinook have to land, ideally the LZ should be at least 35 yards wide and 100 yards long, with an obstacle clearance ratio of 1 in 10. There will be variations on this figure, both ways, depending on altitudes, temperatures, gross weights of the aircraft and wind strengths. If the ground is not level, upslope landings are preferred for several reasons; one reason being that in earlier Chinooks the main brakes work on the forward wheels only. (The forward wheels touch ground first in an upslope landing).



(US Army)

CH-47C at rest with the ramp partly lowered. This aircraft has two T55-L-11 gas turbine engines, each capable of developing 3,750 shaft horsepower under certain conditions. The hook has a 20,000 pound limitation.

Water Operations

As its fuselage is watertight the Chinook can be landed with a forward speed of up to 30 knots on water. Hovering to, taxi-ing on and take-off from water present no unusual difficulties. Water operations are restricted to Sea State 2, which by way of interpretation means 7 to 10 knots wind, large wavelets, crests begin to break, scattered white-

caps, the average heights of the wave less than one foot. At the moment night water operations are not permitted.

Chinook Utilization and Employment Handbook

The Chinook unit publishes this handbook for issue to users. Points such as loading, loading zones and water operations are covered in much greater detail than given here. Other subjects covered are:

<i>Description.</i>	<i>Paratrooping.</i>	<i>Resupply operations.</i>
<i>Safety.</i>	<i>Radios.</i>	<i>Night operations.</i>
<i>Preparation of loads.</i>	<i>Capabilities and limitations.</i>	<i>Aircraft recovery.</i>
<i>Conduct of move.</i>	<i>Planning an airmove.</i>	<i>Armament.</i>
<i>Extractions.</i>	<i>Pickup zone organisation.</i>	<i>Marshalling.</i>
<i>Typical loads.</i>		

Dollars and Cents

Helicopters are expensive pieces of machinery and big helicopters are very expensive to buy and operate. Perhaps for \$A1.7 million you could buy one CH-47C ready to fly with a few radios and a voice security system. But that is hardly half of the story. To this must be added a range of spare parts (say for five years) to cover each aircraft programmed to fly perhaps 35 hours a month. Expensive items such as rotor blades have set life — 3,600 hours for the forward blades, 1,500 hours for the aft. Engines must be changed at 300 hours, though this figure may soon be amended to 600 hours, then eventually 1,200 hours. Other items which add to the cost per unit aircraft are workshop equipments, extra hangarage, freight and overseas training.

The maintenance manpower bill compared with simple helicopters such as the Iroquois is relatively high — about 19 maintenance manhours per flying hour for the Chinook after the aircraft has been in service about three years.

But in the long run, of course, these costs must be related to what such an aircraft means to the Army.

The Word Chinook

With perhaps a certain amount of unconscious irony US Army aircraft are named after Indian tribes. Webster's Dictionary defines 'Chinook' as 'any of the various Penutian tribes formerly inhabiting the Columbian River Valley.' □

Education or Training: Is That The Question?

Captain A. Sandery

Royal Australian Army Educational Corps

Weapons are an important factor in war, but not the decisive factor; it is people not things, that are decisive.

—Mao Tsetung

EDUCATION is an essential and expensive process for any nation, or for that matter, the armed forces or army of any nation. Professor Karmel (Vice Chancellor of Flinders University) has postulated that 'there are three important ways in which education impinges on the productivity of an economy:

- Through the skill of the whole work force.
- Through the ingenuity and inventiveness of technology and scientists.
- Through the knowledge and understanding of administrators.

The effect is felt not only on the absolute volume of goods and services which the nation produces at any one time, but also on the annual rate of growth of that production . . . A substantial educational effort is both a cause and a result of the wealth of nations. Over 80

Captain Sandery was commissioned in the Royal Australian Infantry (CMF) in 1964 and appointed lieutenant in the RAAEC in 1965. He is an Associate of the University of Adelaide in Arts and Education and holds a Diploma of Teaching from Wattle Park Teachers College. He has served at the School of Military Engineering, PNG Training Depot, 2 PIR Wewak, RAEME Training Centre and HQ AFV (Force Education Officer). Currently Captain Sandery is an instructor at AHQ (Trg) and is responsible for the preparation of Audio Visual Training Aids. This paper was an entry in the 1969 AMF Gold Medal Essay Competition.

per cent of all expenditure on education comes from government sources. The decision to allocate more or less money to education is in the main a political decision, depending on the competing claims of health, defence, national development, etc. Australia compares unfavourably in expenditure on education with other countries.¹ He concludes:

- Education is vitally important to our economy.
- The mechanism by which we allocate resources to education is faulty.
- Our performance compared with other countries is unfavourable.
- We ought to devote a higher proportion of our resources to education.²

While it is not possible to apply these conclusions directly to military education, it does appear that increased expenditure in both financing, and research towards, military education is vitally important for efficiency and proper utilization of manpower and material resources.

Professor Zelman Cowen (Vice Chancellor of Queensland University) has written that '... the scientific and technological developments during and since World War II have revolutionized not only weapons, but also the associated communications and logistic support systems.'³ He goes on to quote from an American statement, 'Advances ... have created whole new occupations and skills within the armed forces. These new skills require more instructional programmes of increasing length and sophistication. The magnitude, complexity and cost of these programmes have become a matter of major concern to the services ... Senior service officers have been unanimous in identifying the need for trained people as their most serious problem.'⁴

The need for a reassessment of educational or training efforts within the Australian Army can be firmly established because any

¹ P. H. Karmel, *Some Economic Aspects of Education*, pp. 1-17 condensed.

² *ibid.*

³ Z. Cowen, Article in the RAAEC Newsletter: No. 3/1969.

⁴ *ibid.*

single operation which costs so much and which is so important to the efficiency and functioning of the Australian Army deserves constant attention. The need for a reassessment of educational or training efforts within the Australian Army is firmly established. As Professor Cowen quoted from Alfred North Whitehead's declaration, 'The race which does not value trained intelligence is doomed',⁵ or as Sir Henry Bland (former Secretary of the Department of Defence) said, in the armed services, 'There is vast room for questioning anything that has been done, without change, for five years, and for imaginative thinking.'⁶

In the Australian Army, little, if any, research has been conducted in the delineation of the areas of education and training. The navy too have not clearly delineated these areas. Their education officers are technical officers/instructors, distinct from other officer instructors so qualified or so engaged. The air force however has moved towards a solution of this problem by amalgamating the two areas and drawing no distinction between them. RAAF education is a part of training and a percentage of training is conducted by education officers.

The army, with its longer standing traditions of educational or training efforts for its soldiers,⁷ has classed education as an Adjutant General's Branch (personal services) and has functionally isolated it from training.

The Australian Army Education Service was re-established in March 1941.⁸ Its aims were twofold:

- To make better soldiers by building and sustaining morale.
- To prepare personnel for their satisfactory re-absorption into civilian life.⁹

⁵ *ibid.*

⁶ Sir Henry Bland, transcript of a film shown at the Joint Services Staff College on 27 January 1970 (unpublished).

⁷ For example: C. E. W. Bean. *The AIF in France 1918, Official History of Australia in the War of 1914-18*, Vol. VI. Outlines an education programme in operation in 1917.

⁸ *The Army War Effort*: 31 August 1944: Part XI Chapter 17: Army Education Service.

⁹ *ibid.*

It is because of these roles, morale and resettlement, that army education has been so long regarded as an A Service. These roles are however not the only ones which Army Education fills. A recruiting pamphlet for education officers issued in 1964 states that the role of the RAAEC '... is to administer, through the medium of education to the efficiency of the Australian Regular Army. It does this by developing in the soldier those qualities on which his military skill is largely dependent — intelligence, sound morale and mental alertness, a task which involves a multiplicity of activities in education and its associated field.'¹⁰ The *Australian Army News Feature*, issued by the Minister for the Army, states that 'Members of the Royal Australian Army Educational Corps (RAAEC) provide the general education service in the Army. Their appointments may vary from teaching apprentices in Victoria to indigenous soldiers in Port Moresby, holding administrative appointments in Sydney or Canberra, or conducting Intermediate Exams in the windswept sand dunes at Vung Tau, South Vietnam.'¹¹

The most generally promulgated authoritative and current statement of the role of army education is to be found in the training pamphlet, *Administration in the Field (Non Divisional)* (1966) Chapter 9, Section 37, which states:

The roles of the Army Education Service are

- a. To keep all ranks informed on current affairs and war aims.
- b. To arrange correspondence courses and part-time civil schooling for all ranks.
- c. To conduct courses of instruction and examination in the subjects appropriate to the various military educational standards.
- d. To provide such facilities as reading rooms, libraries, record libraries, and cultural and recreational activities of an educational nature as conditions permit.
- e. To conduct language training for selected personnel and assist in the instruction of English to allied troops if required.

¹⁰ Army Recruiting Pamphlet for RAAEC Officers — 1964.

¹¹ *Army News Feature* No. 3/69: Minister for the Army, p. 2.

Advice on educational matters and technical control of educational resources is provided by the inclusion of a staff officer, education, on the Headquarters Communication Zone. He has an assistant who may be used for training. The resources available within the communications zone consist of:

- Unit education officers within general hospitals, and assistant instructors within convalescent training depots, both provided to cater for patients being treated.
- An education unit consisting of a headquarters and up to four detachments, each of four instructors, for general deployment as required to fulfil the tasks outlined in the previous paragraph.

To summarize, it seems clear that there is a need for a new approach to the training and education relationship within the army and a meaningful reassessment of their roles, because:

- The education/training relationship in the Australian Army has remained static for not five years but nearly thirty years.
- There is a need for more specialists in the Australian Army for the reasons stressed by Professor Cowen.
- There is an economical need to revise our ideas on education and training for the reasons stressed by Professor Karmel.
- Many people in the Australian Army are unaware of the importance of education as a process and education as a corps. This is revealed in the various definitions and lack of definitions of the role of the RAAEC and in the current de-emphasizing of the RAAEC function in training, as highlighted by the recent lowering, and in some cases removal, of the educational requirements for promotion of other ranks.

Other armies however have tackled the problem of education and training by delineating their areas and their functions. In respect of the areas of education and training, one US publication states, 'A number of instructional authorities distinguish between training and education. For use in deriving instructional objectives, the following distinction is proposed: Whether the context is for training depends on the specificity of the work performance situation from which the objective was derived.'

If the intended work situation is defined such that very specific actions are required of the student it seems more meaningful to think in terms of "training objectives". For a more general work situation, the skills and behaviour determined to be terminal objectives would be called "educational objectives".

"The terms "training" and "education" actually represent two ends of a continuum or "yardstick". The more specific the application of the intended performance, the more reasonable to call it training; the more generalized the application, the more it would seem to represent education. Most instruction, of course, is a combination of these two kinds of objectives. Thus, an insistence upon making the distinction may lead to the misconception that, if the instructional programme is called "training", then every objective in the programme must be directed toward specific aspects of job performance. In other words, the distinction can have the effect of, improperly, limiting the kinds of activities or learning experiences contained in the course."¹²

With respect to the functions of education and training, 'The United States Army does not have a military unit or corps charged with responsibility for civilian type education services such as those carried by your Royal Australian Army Education Corps or the equivalent organization in the British Army. Instead, Department of the Army has established a general educational development program, staffed and directed by professional civilian educators. Courses of study are designed to raise the educational level of military personnel to the minimum goals established for enlisted men or commissioned officers.

'Educational objective for enlisted men has been defined as completion of high school or its equivalent. For commissioned officer personnel, completion of a baccalaureate degree is listed as the minimum level of education desired. In addition to assisting in the achievement of these academic levels, the general educational development program also provides instruction which is related to military occupation specialities. Other areas of instruction which are of functional importance for the serviceman's career are included.

'There are approximately 300 professional personnel who direct and administer the program throughout Department of the Army.

¹² Harry L. Ammerman, *The Derivation, Analysis and Classification of Instructional Objectives*, et al USAD 633474 May 1966.

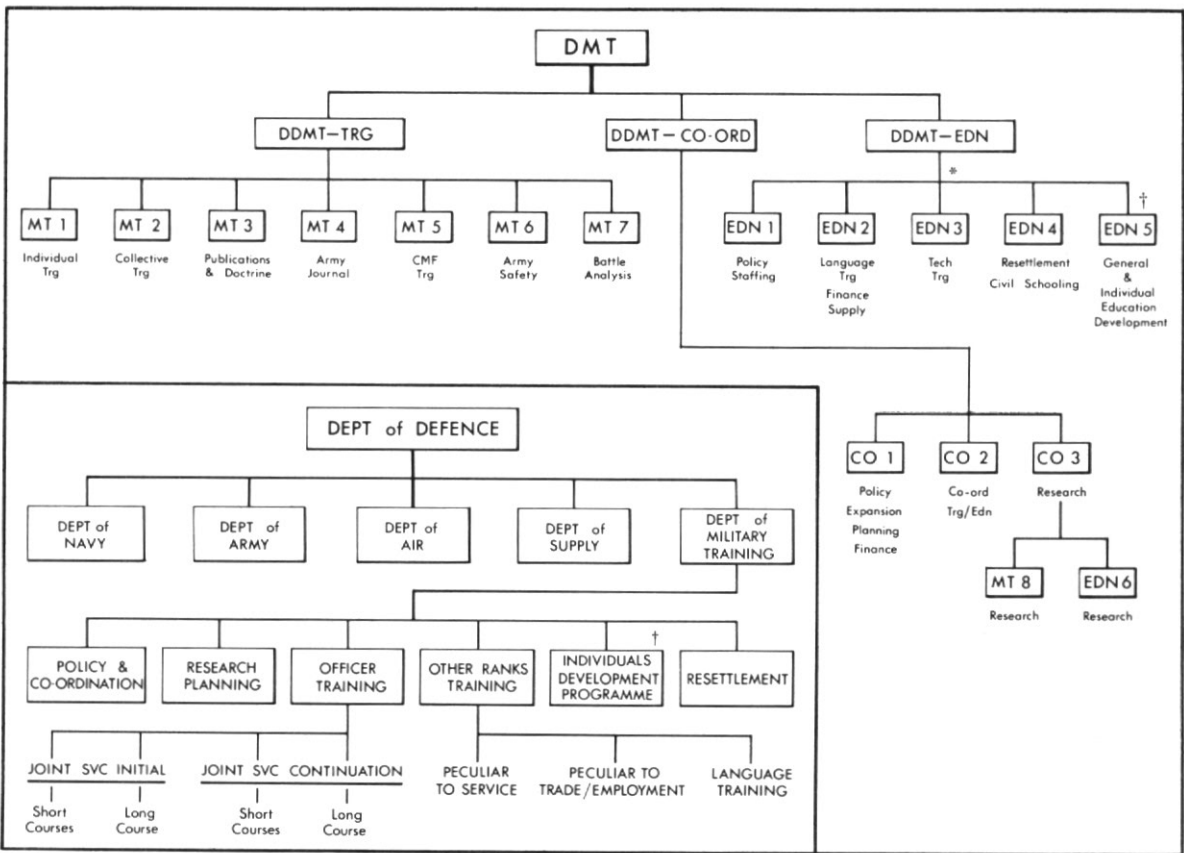

* Unpublished paper on the organization of the RAEC of 25 May 1966.

† A. N. Brunch, 'The Army's Open Door to Learning,' *US Army Information Digest* November 1963.

Education centers are authorised for military posts or installations which have a military assigned troop strength of 750 or more.¹³

These two statements disclose a dichotomy of levels of the education and training relationship within the US Army. On one level, the function of education and training, the general educational development programme, staffed by civilians, caters for advancement in both personal educational standards and in certain military areas, thus effectively combining education and what would be called training in the Australian Army. On the other level, the areas of education and training, these terms are seen as representing the two ends of a continuum and most military instructional programmes would contain both types of objectives. Although a dichotomy of levels has been disclosed, education and training are not functionally isolated as in the Australian Army.

It would appear from these American statements and from the various appointments held by education officers in the Australian Army that education and training should not be distinguished and that while education can be less specific than training, it is an essential ingredient of the overall aim of maintaining an efficient army and Education, as a corps, has this function and other non-training functions to fulfil. As the Director of Army Education has said, 'Perhaps the lines between training and education are more blurred than our professional pride cares to recognize, but in broad terms, it is probably valid to say that training is more defined and limited in its objectives than education.'¹⁴ However, the most successful compromise would seem to be to picture training as a part of education in concept and as a process, but to include education as a part of training within a military function. Illustrated are two outline organizations which include this proposal.

These proposals would not only clear up the present 'mystery' in the Australian Army between education and training but they would also utilize to the best effect our resources of manpower and material which is, economically, a vitally necessary move, and they could solve the problem of the shortage of specialists in the army by providing training programmes where the need is greatest — within the army.

¹³ Personal letter from Major General J. C. Lambert, Adjutant General 10 May 1966.

¹⁴ Brigadier E. C. Gould, 'Introductory letter to RAAEC Members,' 30 June 1966.

'I am tired of hearing that the hope of my country lies in my generation. If you give me the same indoctrination as a child, how can you expect me to be any different from you?'¹⁵

Not only have the educational aspects of training been trodden down by the inertia of thirty years inactivity, lack of research and liaison, but the training aspects of education have also lapsed. Fortunately, not all countries have allowed this to happen. The Swiss Government have distributed the Swiss Civil Defence Manual free to every house in Switzerland. 'Whoever wants to preserve peace must be ready to resist any threat. For Switzerland, vigilance and readiness have been constant necessities, that is, in every epoch. They are today . . . the preparation is not only external, it is also consciousness of all the possible dangers.'¹⁶ The book goes on to devote the last 100 or so pages of its 300 pages to Psychological Warfare.

Education may be indoctrination, as in guerilla type warfare. Che Guevera said, 'The important thing, that which must never be neglected in a school for recruits is indoctrination; this is important because the men arrive without a clear conception as to why they come, with nothing more than very diffuse concepts about liberty, freedom of the press, etc., without any clear foundation whatever.'¹⁷ It should also be something more: 'Reading should be encouraged at all times, with an effort to promote books that are worthwhile and that enlarge the recruit's facility to encounter the world of letters and great national problems. Further reading will follow as a vocation; the surrounding circumstances will awaken new desires for understanding in the soldiers. This result will be produced when, little by little, the recruits observe in their routine tasks the enormous advantages of men who have passed through the school over the remainder of the troops, their capacity for analysing problems, their superior discipline, which is another of the fundamental things that the school should teach.'¹⁸ Using the words of Sir Henry Bland, 'I see the need for many changes: The need to induce a new community evaluation of our Armed Forces which

¹⁵ 'The Schools that I'd Like', *Penguin Education Special*, (unnamed 15 year-old girl).

¹⁶ 'Neutral Swiss have a little red book', *The Canberra Times*, 23 January 1970.

¹⁷ Che Guevera, *Guerilla Warfare*, Penguin.

¹⁸ *ibid.*

will produce more lively response from its young men. Seniority, which is only one aspect of orthodoxy, needs to be banished to the small place it has in our public service and in industry where the top posts go to the best equipped, irrespective of age. Remember that if things remain as they are, the situation of the services relative to other sectors of our community won't even be maintained; it will decline.¹⁹ □

Man is and will remain the essential element in war. Men, not machines, win or lose the battle. Machines cannot wage war; they can only increase the effectiveness of man. The importance of the individual increases with the complexity of the weapons he must employ. The importance of the man will increase until we reach the stage of having weapons which can think and improvise; which can meet reverses with resolution; and which can match hardship and danger with devotion and courage, and carry on to final victory. There is no such machine on the horizon.

—General Lyman L. Lemnitzer, US Army (Retired).

¹⁹ Bland. *op. cit.*

The Sioux Wars, 1854-91

Staff Cadet C. D. Clark

**Many, if not most,
of our Indian wars have had
their origin in broken promises
and acts of injustice on our part.**

—Rutherford B. Hayes (1877)
(Nineteenth President of the
United States of America).



IT is difficult to consider the Sioux wars in the United States as worthy of any serious study. To most people today, the Indians remain those undying if often-killed favourites of American entertainment and our minds are forever dominated by the image of hordes of yelling braves, bedecked in feathers and war-paint, galloping around a circle of wagons amid the crash of gunfire and volleys of arrows. In presenting Indian warfare in this manner Hollywood has rendered history a great disservice, for romanticism has tended to obscure the realities of a unique period in America's past. The aim of this paper is to study an early example of irregular or guerilla warfare in which Americans were involved. Before looking at the problems confronting the United States Army and the reasons for the final defeat of the Sioux, the major battles and incidents of the wars are briefly sketched and their significance discussed.

Significance of the Sioux wars

Of all the conflicts between whites and Indian, the wars on the Great Plains of the American mid-west were the biggest, the bloodiest, and militarily the most interesting. The thirty tribes who lived the nomadic existence of trailing the great buffalo herds were the last to taste the bitterness of inevitable defeat before a prodigious flow of settlers. Following the Lewis and Clarke expedition across the continent in 1804-06, the area between the Missouri River and the Rocky Mountains had been dubbed the 'Great American Desert', land unfit for white habitation. Consequently settlers developed the two coastal

Staff Cadet Clark, of Victoria, is a second year Arts student in the Faculty of Military Studies, University of NSW, at the Royal Military College, Duntroon, and has previously contributed to Army Journal. This paper was read to the Bridges Society, of the RMC on 28 August.

regions, ignoring the vast open, seemingly barren, ranges of the high plains until soon after the end of the civil war, when the myth was dispelled. When the plains tribes saw their lands diminishing with alarming rapidity, their reaction was completely predictable; proud and warlike people, they used force to keep the invaders out.

Although the tribes of the plains were better equipped and had more advantages than other tribes who had previously resisted the white encroachment, history proved their struggle too to be futile. In general the wars with the plains Indians were more mopping-up operations than major contests, and diseases such as cholera, measles and influenza took a heavier toll of the tribes than did deaths sustained in battles. The United States Army was never in any condition to reduce the recalcitrant tribes by pure military might alone, and the subjugation of the plains Indians was only achieved through the adoption of other means, discussed later in this paper.

That the Indian wars were an important phase in the development of America's west there can be little doubt, but we may well ask what made the Sioux wars so distinctive. We are given a clue in Garraty's comment that 'Custer's Last Stand will be remembered as long as Gettysburg or Pearl Harbor.'¹ Although Sioux tactics did not markedly differ from those of neighbouring tribes, at least until 1876, they achieved the greatest and most spectacular successes against the army. Because they succeeded in winning battles — although they were inevitably losing the war — the Sioux earned the grudging respect of Americans, civilian and soldier alike. It had been the Sioux who had kept the plains in a constant state of turmoil and terror for over twenty years, causing commanders such as Terry, Crook, Custer, Miles and Sheridan, to be pitted against the greatest Sioux leaders: Crazy Horse, Red Cloud, High-Back-Bone, Gall, and the most enigmatic figure of all, Sitting Bull. And, when it came time for the conquerors to memorialize the people they had destroyed, it was the Sioux warrior, the scourge of the wild west, who best fitted the concept of the 'noble savage'. The Sioux were hated and dreaded, yet their skill and courage in battle earned them the grudging respect of their adversaries. They were considered among the finest of all the Indian tribes encountered by the whites.²

¹ J. A. Garraty, *The American Nation*, (New York 1966), p. 472.

² J. T. Adams (ed.), *Dictionary of American History*, Vol. V, (New York 1940), p. 85.

Significantly it was the Sioux who, in 1868, emerged victorious from the Red Cloud war which had been raging for two years. The American Government acceded to Sioux demands that the Bozeman Trail (see fig. 1) be closed and the forts protecting the trail be abandoned, making this, as Ryan comments, 'the first and only peace treaty dictated on the terms of an enemy who had beaten them in their own country.'³ On occasions however, other events helped give the Sioux wars a significance greater than perhaps was deserved. Although the defeat of the Seventh US Cavalry at the Little Big Horn on 25 June 1876, with the deaths of General Custer and nearly three hundred men of the regiment, was the worst reverse the army had suffered at the hands of the Indians, there can be little doubt that the shock to the American public was greatly magnified by the fact that the news of the catastrophe came right when all America was celebrating a hundred years of progress and achievement since independence with a great Centennial Exhibition at Philadelphia. The press coverage the Little Big Horn received was greater therefore than it might otherwise have warranted, and the feelings of humiliation suffered by Americans gave the incident an exaggerated importance in the nation's history.

Brief History of the wars

Much of the Sioux success can be attributed to their numbers, as they were the largest single tribe on the plains, embracing an estimated fifty thousand people in a loose confederation of numerous bands.⁴ A second important factor can be discerned through the history of the Sioux. Originally they had inhabited territory around the southern end of Lake Superior and here, from the early 1600s, they were at constant war with the neighbouring Chippewa.⁵ When their enemies were supplied with firearms by the French, the Sioux were steadily driven west (see fig. 1), into territory claimed by other tribes. In the resulting wars the

³ Major M. J. Ryan, 'A Good Day To Die', *Australian Army Journal*, No. 237, February 1969, p. 36.

⁴ The Sioux can be divided into three main groups: the Santees or Eastern Sioux of the upper Mississippi and Minnesota rivers; the Yankton and Yanktonais of eastern South Dakota; and the western Sioux, the Tetons, of the high plains — the Ogllalas, Hunkpapas (Uncpapas), Minneconjous, Brulés, Sans Arcs, Two Kettle and Blackfeet (as distinct from the other plains tribe also known as the Blackfeet).

⁵ The name 'Sioux' dates from these wars. Actually an abbreviation of the Chippewa word 'Nadowessiou', the name meant 'snake', that is 'enemy'. The Sioux called themselves 'allies' — 'Lakota' in Teton, 'Dakota' in Santee, and 'Nakota' in the Yankton dialect.

Sioux were victorious, and between 1780 and 1830 they moved out onto the plains. Thus from an early stage, the Sioux had been forced to fight for their existence, and with warfare such a constant element in their lives, needless to say they developed great skill in the art.

The Sioux had been people of the forests and lakes, but once on the plains they adopted the way of life and culture of the nomadic buffalo-hunting plainsmen. Both through trade and through raids, the Sioux acquired the horse, and mounted on stocky ponies (descendants of horses originally brought to the New World by the Spanish), the Sioux found themselves possessed of mobility never before experienced. When Americans came into contact with the Sioux and other tribes of the Great Plains — notably the Cheyenne and the Arapaho — they found themselves facing a new kind of foe, one that was aggressive, geared to a life of war, and possessing great mobility.

The US Army first clashed with the Sioux at the so-called 'Grattan Massacre'⁶ of 19 August 1854, when a party of thirty soldiers from Fort Laramie, under Lieutenant John Grattan, were killed when they demanded payment for a \$10 cow slaughtered by a Sioux brave. Although Grattan appears to have been quite unreasonable and antagonistic towards the Sioux, and the Indians to be somewhat justified, the army avenged the incident with the near annihilation of a whole village at Ash Hollow in September of the following year. Such incidents on a smaller scale were frequent, but the army was able to exercise considerable control over the frontier. Minor outbreaks such as the Spirit Lake Massacres⁷ were usually the work of hot-heads and although they posed no military threat, they served to greatly embitter relations between the white settlers and the Sioux.

The influence of the army was removed from the frontiers in 1861 however, when the nation became involved in tearing itself apart from within during a bloody civil war. Until the end of the war in 1865, the whole Indian population of the plains became restless and settlers along the frontier became uneasy. Already the process of dispossessing the

⁶ It is curious to note that all Sioux victories are termed 'massacres', for example, Minnesota Massacres (1862), the Fetterman Massacre (1866) and the Custer Massacre (1876) among others, while all US victories are called 'battles'. One exception is the fight at the Rosebud Creek (1876), and both sides claim it as a victory.

⁷ Between March 7-13, 1857, thirty-eight men, women and children were killed and five women carried off in raids on six cabins on the Okoboji Lakes and Spirit Lake, Iowa, by a few Sioux renegades under Inkpaduta (Scarlet Top).

Sioux of their lands through treaties was well advanced, and in Minnesota the Santee Sioux had been deprived of their hunting grounds with promises that the Government would provide for them. With the Government distracted by the war, grafters and corrupt agency officials had a free hand and the treaty obligations to the Sioux were not observed in 1862. Rather than face the prospect of starvation during the coming winter, the Santee under their chief Little Crow, struck out in desperation and Minnesota became submerged in a blood-bath

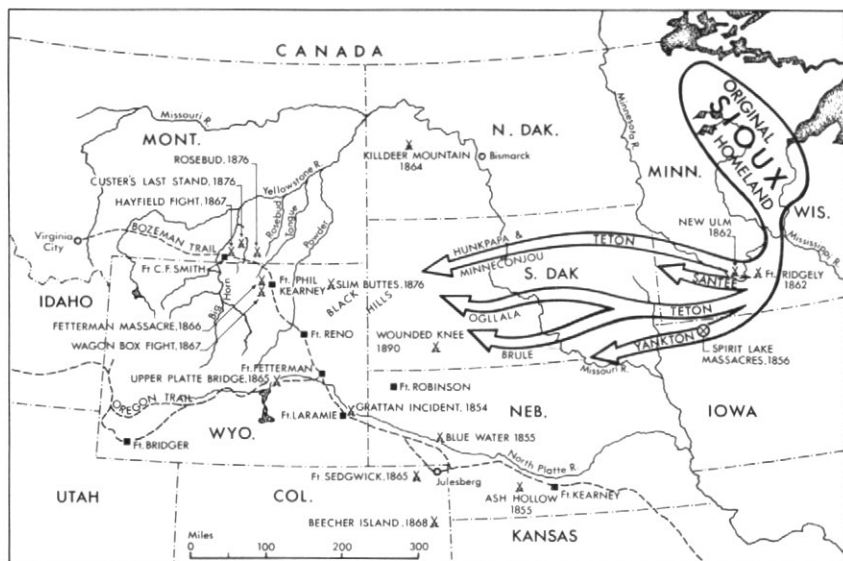

lasting about six weeks, during which time some five hundred settlers died. The army hurriedly concentrated troops and ruthlessly crushed the uprising. At Mankato on 26 December 1862, thirty-eight Sioux were hanged as ringleaders, President Lincoln having commuted the sentences of all but these out of over three hundred. By far the most important consequence of the uprising, was that between 1863-65 expeditions were sent in pursuit of Santee fugitives. These expeditions pursued their quarry out onto the plains, stirring up the Teton bands until by 1865 the whole Sioux nation was hostile. They joined in an alliance with their former enemy, the Cheyenne — an alliance which was to remain firm until after the victory at the Little Big Horn — and participated in such actions as the Platte Bridge Fight of 26 July 1865.

With the Sioux up in arms, movement along the Bozeman Trail became hazardous, and in an effort to protect traffic the army erected three forts: Phil Kearney, Reno and C. F. Smith. This action provoked a full-scale war with the Sioux, led by the Oglala Sioux chief, Red Cloud. The forts were kept under virtual siege, and it was during this so-called 'Red Cloud war' that three major actions occurred — the Fetterman Massacre (21 December 1866), the Hayfield Fight (1 August 1867) and the Wagon-Box Fight (2 August 1867). These clashes added weight to the suggestions of the peace faction in Washington that it would be 'cheaper to feed than to fight' the Sioux, and a peace treaty was concluded at Fort Laramie in 1868 complying with Sioux demands for the closure of the Bozeman Trail.

A general lull in fighting followed the signing of the treaty, but incidents were frequent and the peace was an uneasy one at best. When Lieutenant-Colonel George Armstrong Custer, the 'Boy General' of civil war fame, was ordered through the Black Hills — the Pah-sapa (sacred hills) of the Sioux — on a survey of likely sites for forts⁸, subsequently discovering gold, open warfare was again a threat. Although the army attempted to have the boundaries of the huge Sioux reservation observed by miners, the cordon was too thin and the task proved impossible. The Sioux were aroused. The whites were clearly not observing the 1868 treaty; the miners fouled the streams and drove off the buffalo. Starvation threatened the Sioux, and hunting parties began leaving the reservation. To officials in Washington the attitude of the Sioux was menacing, and the whole situation appeared to be getting out of hand.

In an incredible piece of stupidity, the Bureau of Indian Affairs, instead of employing the utmost tact and discretion, issued an ultimatum for the Sioux to return to their reserves by 31 January 1876. The chiefs simply replied that they were 'too busy'.⁹ The expiry date passed, and the army prepared to act against the 'hostiles'. General Sheridan in Chicago issued orders for a massive three-pronged drive to be made against what were believed to be small bands 'somewhere' south of the Yellowstone River, and in between the Big Horn and Rosebud.

⁸ See E. I. Stewart, *Custer's Luck*, (Norman, Okla. 1955), p. 62. The expedition was certainly not, as one account has it, to relieve the boredom of Custer's troops who had been snowbound during the long winter.

⁹ *ibid.*, p. 77.

The southern column under General Crook was first to discover that this would be no normal Indian campaign. Instead of small hunting parties, Crook's force of fifteen hundred men was stopped cold by an equal force of Sioux at the Rosebud. In an amazing six-hour battle over a sprawling battlefield, five miles by two, the Indians inflicted heavy loss on Crook while sustaining relatively light casualties themselves. Crook, who had been confident of beating any Sioux he found, was stunned and shaken, and with many wounded, and short on supplies and ammunition, he retired from the campaign.

In later years Crook was to claim that since the Sioux had left him in possession of the battlefield he had won the battle, but Vaughn says:

... it seems clear that the Indians won the battle for they succeeded in keeping the army away from their camp and prevented Crook from joining Terry and Custer in the concerted action against them... [and] with Crook out of action Custer was an easy prey for the Indians.¹⁰

Nine days later, on 25 June, Custer's Seventh Cavalry also suffered defeat, in even more spectacular fashion. In a battle which still remains a raging controversy, Custer's immediate command of five companies, just over two hundred men, was annihilated.¹¹

Historians remain divided over where the blame should lie; some accuse Custer of rashness, others accuse Custer's subordinates, Reno and Benteen, with cowardice. Too few have realized that the 1876 campaign was a departure from the usual pattern of Indian warfare, and that there are numerous extraordinary factors evident at the Little Big Horn fight¹², so that the débâcle can not be entirely explained away in terms of bad generalship. As one account comments, Custer 'seems

¹⁰ J. W. Vaughn, *Indian Fights: new facts on seven encounters*, (Norman, Okla., 1966), p. 144.

¹¹ The Seventh Cavalry suffered 264 men killed in the Battle of the Little Big Horn, but only 202 of these died with Custer. See map of graves, W.A. Graham, *The Story of the Little Big Horn: Custer's last fight*, (Harrisburg 1959), p. 179.

¹² For the best accounts of the battle see Graham's *The Custer Myth*, (Harrisburg 1953), and the work by the same author quoted above. Also see Frazier Hunt's biography *Custer: the last of the cavaliers*, (New York 1928), and the biography by Jay Monaghan, called *Custer: the life of General George Armstrong Custer*, (Boston 1959). One of the most detailed and balanced accounts of Custer and the Last Stand is Edgar Stewart's *Custer's Luck*, previously cited, while for an interesting insight into Custer's mind see G. A. Custer, *My Life on the Plains*, originally published 1878, but reprinted in Chicago, 1952. For an anti-Custer view F. F. Van de Water's *Glory Hunter*, (New York 1934) is well worth reading, as is the article by Major Ryan, 'A Good Day To Die', previously mentioned, although unfortunately it contains numerous unsubstantiated assertions and historical errors.

to have ridden into something that no white man would have believed possible... the chiefs had concentrated at least 2,500 warriors, perhaps 4,000, the largest Indian army ever assembled at one time in the United States.¹³ These warriors were better armed than any Indian army had ever been and possessed a seemingly inexhaustible supply of ammunition. Army intelligence had failed to realize the danger, and the columns were operating virtually blind, unable to communicate with each other.

The army hunted down the Sioux and Cheyenne responsible for the Custer battle, and they were either forced to surrender, massacred, or chased into exile in Canada. By 1877 the Sioux wars were practically over. The final episode came with the Ghost Dance scare of 1890. The Sioux, clutching at any straws of hope that the old life could be restored, turned to a ceremony imported from the Paiute. The ritual, originally started in a peaceful spirit, became a symbol of revenge and victory over the whites and promised the coming of a Messiah and a new world.¹⁴ Army attempts to put down what they feared would start a full-scale uprising led to the murder of Sitting Bull, and the whole situation, called by some the 'Messiah War'¹⁵, ended finally in a bloody tragedy at Wounded Knee Creek on 29 December 1890. Bands of fugitives surrendered in January of the following year and the subjugation of the Sioux was complete.

Problems Confronting the U.S. Army

In giving such a brief account of the wars, it cannot be easily appreciated how difficult the task of the military in fact was. Westward expansion after the civil war had met with the most bitter and determined resistance yet encountered on the frontier. It was Sheridan, one of the most distinguished cavalry generals of the civil war, who ranked the Sioux as the 'finest light cavalry in the world'. The problem lay in the fact that in the immediate post-war years, the army found itself divided on several fronts, allowing an effective concentration on none. While the Sioux raided across five states, Fenians, members of a brotherhood of Irish nationalists, were disrupting Canada and posing a

¹³ R. N. Current, T. H. Williams, F. Freidel, *American History: A Survey*, (New York 1967), p. 512.

¹⁴ Eugene Rachlis, *Indians of the Plains*, (New York 1960), p. 114.

¹⁵ For the best account of the 'Messiah War', see R. M. Utley, *The Last Days of the Sioux Nation*, (New Haven 1963).

potential threat to the US, and in the south a French-backed empire, under the Austrian archduke Maximilian, existed in Mexico and, it was feared, was in sympathy with the but-recently vanquished Confederacy, which also had to be garrisoned by the Army.

Despite the great military strength of the two opposing armies during the civil war, there were insufficient troops to deal with the Indians in post-war years. After four years of bloodshed the American people were sick of fighting and of armies, and Congress became anti-militaristic and parsimonious. By August 1866 over a million men had been mustered out of service so that by the end of the year barely 10,000 men remained in uniform. The army remained in a very depressed condition; the life was hard and dangerous and in the post-war years all ranks were receiving less pay than in the years before the War. With little hope of expansion of the services, there was little hope of promotion, and consequently while the rate of recruitment was low the desertion rate was high, although these rates were reversed during periods of economic difficulty. There was little concern for the lot of the soldier and, as Weigley points out, public fears for the soldier's safety engendered by reverses, such as the Little Big Horn, were soon forgotten.¹⁶

The problem was therefore to make inadequate numbers spread over as wide an area as possible. In 1869, the army was scattered over some two hundred and fifty posts, and this was to create great problems. With large distances between posts which were often manned only by small garrisons, junior officers often found themselves in charge and away from the immediate guidance of superiors. Great distances meant supply was difficult, as was the maintenance of communications. This last factor was crucial, because with the Sioux so mobile it became hard to keep trace of the movements of war parties. Still, despite the seemingly insurmountable problems, the army was remarkably successful and suffered surprisingly few reverses. The main danger was one of a defeat in detail, where the Sioux were able to concentrate enough warriors to wipe out an army detachment, such as the Fetterman Massacre.

The government itself was uncertain as to how it should deal with the Sioux, and ludicrous situations resulted. Settlers along the frontier demanded the army protect them from the Sioux, but when the army complied, the 'bleeding heart' faction in the east branded them butchers

¹⁶ R. F. Weigley, *The History of the United States Army*, (New York 1967), p. 271.

of innocents. Similarly, while the army diligently tried to stop Sioux incursions, the Bureau of Indian Affairs was supplying the Indians with rifles and ammunition, ostensibly for hunting purposes. Custer complained, somewhat sarcastically, that the Indians were being supplied with

either a breech-loading rifle or revolver, sometimes with both — the latter obtained through the wise foresight and strong love of fair play which prevails in the Indian Department, which, seeing that its wards are determined to fight, is equally determined that there shall be no advantage taken, but that the two sides shall be armed alike; proving, too, in this manner the wonderful liberality of our Government, which not only is able to furnish its soldiers with the latest improved style of breech-loaders to defend it and themselves, but is equally able and willing to give the same pattern of arms to their common foe. The only difference is, that the soldier, if he loses his weapon, is charged double price for it; while to avoid making any such charge against the Indian, his weapons are given him without conditions attached.¹⁷

The mobility of the Sioux created other problems too, since, in typical guerilla style, they carefully avoided the set-piece battle unless, as in 1876, it suited them. The Sioux were operating over familiar ground against an enemy who found it difficult to collect accurate intelligence or make adequate reconnaissance, conditions ideally suited to the Sioux tactics of ambush and hit-and-run. In 1876 the army believed it was operating against only a few hundred Sioux, whereas in reality over 28,000 Indians were absent from the reservations¹⁸, meaning there were possibly up to 6,000 warriors ready to fight.

Since the Sioux were an elusive enemy, able to strike rapidly at points many miles apart, the brunt of the fighting fell on the twelve cavalry regiments, the best of which was the Seventh. Artillery, on the occasions when the problem it created for mobility could be overcome, proved useful, and Gatling guns also were of great value, although they too created problems. Mounted on gun-carriages and drawn by condemned horses, the Gatlings were much too heavy and slow to accompany cavalry.¹⁹ Custer had declined the offer of a battery of them before setting out for the Little Big Horn, and his judgement proved sound when they lagged far behind the second column under General Terry.

Infantry was never a deciding factor in the Sioux wars, as the foot soldiers, or 'walk-a-heaps' as the Indians called them, were too slow to worry the mounted warriors. There was however, another

¹⁷ G. A. Custer, *My Life on the Plains*, p. 45.

¹⁸ *The Centennial of the United States Military Academy at West Point, New York, 1802-1902*, Vol. 1, (Washington 1904), p. 572.

¹⁹ Paul Wahl & Donald R. Toppel, *The Gatling Gun*, (London 1965), p. 81.

factor involved. Whereas the inaccurate cavalry carbines had a range of six hundred yards, the infantry were equipped with the 'Long Tom' which possessed a range of a thousand yards. The Sioux feared and carefully avoided these accurate weapons and this probably explains why, at no stage in the Battle of the Rosebud, was Crook's infantry in trouble.

The majority of the cavalry officers had seen action in the civil war, and had to adjust their ideas to the guerilla-style conflict waged by the Sioux. The ranks of the companies included large numbers of inexperienced and untrained troops²⁰, and consequently it was often found that the Sioux were better shots than the ordinary trooper. Fire control was also very bad, an important factor as it would certainly have compensated in some measure for the fact that the Sioux were often better armed, having bought rifles from gun-runners. Certainly a decisive factor at the Little Big Horn was the excellent rifles possessed by the Sioux, and the inferior cartridges used by the troopers which jammed their weapons.

Overcoming the Problems

As a counter to the mobility of the Sioux, railways proved invaluable, as they facilitated the movement of supplies and troops in all weather, enabling the army to operate at times when the Indians were snowed in. Artillery pieces could now be swiftly moved up once the location of the hostiles had been notified via the new innovation of the telegraph — a fact the Sioux were not slow to realize and counter with the destruction of lines and attacks on maintenance gangs.

Problems of inadequate reconnaissance and intelligence were overcome by the use of Indian scouts. The army found willing helpers in the traditional enemies of the Sioux — the Arikara, Crow and Shoshoni — who quite often also proved their worth fighting alongside the troops. Emphasis was placed on fire-power to compensate for small numbers, and thus at the Wagon-Box Fight some thirty soldiers and civilians armed with new repeating rifles were to soundly defeat several hundred Sioux, though this counter was negated as the Sioux gradually came to acquire improved weapons also.

Although the Sioux were cunning and crafty, and possessed the tactical ability, horsemanship and eye for terrain of the cavalryman, they

²⁰ Of the seven hundred men who rode with Custer in June of 1876, it has been estimated some 30-40% of the recruits in each company had had no prior service. See W. A. Graham, *The Story of the Little Big Horn*, p. 118.

lacked the discipline and leadership of the army. The fact that the Sioux warrior fought as an individual, and that even the greatest chiefs held but tenuous control at best, could not be compensated for by the ability to cover fifty miles a day with ease. It was unusual for Indian leaders to give much thought to tactics, and even less attention was given



Union Pacific Railroad

Hostile Sioux chiefs (l to r) Sitting Bull, Swift Bear, Spotted Tail, and Red Cloud, and their interpreters.

to strategy. Sioux chiefs 'ordinarily rose to power through demonstration of fitness for leadership, but their power consisted largely of the weight of their personal influence'²¹, and consequently, unlike Crazy Horse who was considered by many historians to have been the ablest Sioux tactician, the 'Stonewall Jackson of the Sioux', few chiefs could exercise direct control over how a battle would be fought. Indian battles

²¹ J. T. Adams (ed.), *Dictionary of American History*, Vol. V, p. 85.

are described in Burns as 'a multitude of single conflicts; there are no ranks, no battalions, no united efforts; "every man for himself" is the ruling principle, and victory depends on personal bravery and good horsemanship.'²² This loose command and attitude of the Sioux that war was some sort of honour game where personal courage was displayed was a distinct advantage for the army, and it was not until 1876 that Sitting Bull starting convincing the Sioux to fight to kill, not to 'count coup' and make 'bravery runs'.²³

Economic Aspects of the wars

Without question the factor that ultimately spelled the end of the Sioux way of life was the disappearance of the great bison herds. The whole Sioux economy was based upon the buffalo; as Stewart says, 'The flesh furnished food; the horns, glue, spoons, and other tools and implements; the dried droppings of the animal, the familiar 'buffalo chips', were used as a fuel; while the hide furnished robes for his bed, a covering for the tepee, and was also made into leggings, bowstrings, moccasins, and sacks.'²⁴ In focusing its attention on the buffalo the army was able to achieve what could not be achieved militarily, for by striking at the economic base of the Sioux it merely became a matter of time before the Indians starved or died of exposure.

In 1871 buffalo hides became a commercial proposition, worth between \$1 and \$3. Between 1872-74 nearly three million animals were slaughtered annually, many not even for the hides but for the tongue (considered a delicacy), or just for sport. Of the fifteen million bison estimated on the plains in 1865, by 1886 only some six hundred were left of the Northern herd, the Southern herd having vanished entirely! Despite all the maudlin sentimentality encountered in the history books, the Indian assisted in his own destruction, for hides became the means by which rifles and trade-goods could be obtained.

²² R. I. Burns, *The Jesuits and the Indian Wars of the Northwest*, (New Haven 1966), p. 222. The writer, a Father Mengarini, was talking about the Flathead confederates to the north-west of the Sioux, but the comment is made that these Indians 'tutored... many Interior tribes in warfare on the buffalo Plains.'

²³ To 'count coup' a warrior struck an enemy with the bare hand, or special coup-stick, and rode away to tell of it. 'Bravery-runs' were the practice of galloping across an enemy's front within rifle range, deliberately daring the enemy to fire.

²⁴ E. I. Stewart, *Custer's Luck*, p. 8.

Some whites saw the opportunity to get rich quick, and a trade in rifles and pistols quickly sprang up in the early seventies. A rifle would cost a warrior \$100 worth of robes, hides or furs, and cartridges could cost as much as 20c each. As Lunt observes, 'The profits were vast, the risk of detection in that wilderness negligible, and the knowledge that the weapons would be used against fellow Americans of little or no consequence.'²⁵ Graft was rife in the administration of President Grant. It was common practice for Indian agents to sell supplies intended for their charges and pocket the profits, and the Minnesota Massacres of 1862 can be directly attributed to this cause, just as the defeats of 1876 can be blamed to a certain extent to the misleading reports of agency officials which were deliberately falsified to gloss over similar iniquities.

Throughout, the Sioux distinguished themselves for their bravery and ferocity in battle. They were honourable warriors fighting what proved in numerous cases to be a not-so-honourable opponent. The old style of fighting emphasized honour and courage, but this attitude was to change when fighting an enemy who believed that 'when dealing with savage men, as with savage beasts, no question of natural honour can arise. Whether to fight, to run away, or to employ a ruse, is solely a question of expediency.'²⁶ It was a new aggressive attitude combined with all the desperate valour of a last-ditch stand which Crook and Custer were to encounter in the ill-fated campaign of 1876.

Conclusion

Although the Sioux wars may be held to be typical of most Indian conflicts, they were unique for their scale, their bitterness, and the degree of success the guerilla tactics of the Sioux enjoyed over a conventional military force. Although the Apaches of the south-west were to give the US Army a more classic example of guerilla warfare, the Sioux had waged war on the same principles with far greater success. Similar problems to those discovered in the Sioux wars were to become apparent to the US Army almost a century later in Vietnam, and it is interesting indeed to note the emphasis in this later conflict again being placed on economic warfare. □

²⁵ James Lunt, *Charge to Glory*, (London 1961), p. 170.

²⁶ General Francis A. Walker, Commissioner of Indian Affairs, in 1871, quoted in R. Hofstadter, W. Miller, D. Aaron, *The United States*, 2nd Edition, (New Jersey 1967), p. 495.

REVIEWS



THE FOURTH DIMENSION OF WARFARE, VOLUME ONE.

Edited by Michael Elliott-Bateman. Manchester University Press,
July 1970.

Reviewed by Lieutenant Colonel P. C. Gration, AHQ Canberra.

IT is difficult to say precisely what this book is about. The title *Fourth Dimension of Warfare* refers to all types of irregular warfare, as distinct from conventional warfare which fills the first three dimensions. The text consists of a series of lectures delivered at Manchester University in 1967 by six speakers who are in the main British World War II experts in irregular warfare. Through discourses on Intelligence, Subversion, and Resistance, they lead up to the main subject of People's War. If there is a single theme, it is probably that People's War has arrived on the military scene as a new, different, and higher form of warfare. It is not synonymous with Mao Tsetung's People's Revolutionary Warfare, but is given a much wider meaning as a general theory of warfare with three principal models — offensive, defensive, and revolutionary. It is implied, if not directly stated, that we will have to adapt to People's War for survival, in the same way as the armies of World War II had to adapt to mobile armoured warfare.

Michael Elliott-Bateman continues to hold some of the fairly extreme positions on People's War that he gave in his earlier book *Defeat in the East*. For example, he suggests that in Vietnam we are witnessing '... a watershed in military evolution — the twilight of a traditional military system and the dawn of a new one that represents a higher order in development.' That this has been a thorough surprise to the West is entirely due to their own narrow conservatism, since there has been a steady and progressive evolution towards modern People's War, discerned and adopted by the East, but ignored by the West. A few gifted individuals in the West, usually civilians such as T. E. Lawrence, have appreciated the possibilities, but have been repressed by the military establishments.

There are some major implications in all this that warrant examination. Is it justifiable to postulate a general concept of People's War where the revolutionary form is only a subsidiary? The idea is bold, but the weight of historical experience must at the very least make the revolutionary form the dominant one. Further, the relationship between the revolutionary and the offensive and defensive forms may be more apparent than real, and is perhaps limited to the employment of guerillas and to subscribing to the doctrine of Indirect Approach.

Of greater importance is the argument that the recent successes of revolutionary warfare are evidence that it, and hence People's War, is in essence a higher form of warfare. This argument confuses principles with their application. Revolutionary warfare does indeed embody those principles advocated by most of the great military theorists from Sun Tzu to Liddell Hart, but so do other forms of warfare. Practitioners of revolutionary warfare have successfully applied these principles to a particular situation, but the essential and universal merit still lies in the principles rather than the particular application.

Mao Tsetung's writings do not add up to a general theory of modern warfare, nor was this his intention. His papers and speeches were prompted by political and military problems encountered by the communists, and were designed to define policy, convince dissidents, and instruct subordinates. The fact that they were occasioned by specific events does not of course necessarily limit their wider application, but it does demand a close appreciation of the context in which they were formed. This could best be described as a revolutionary environment where a special set of social, political, economic, and geographic conditions existed. These conditions not only allowed revolutionary warfare to be used, but made it highly probable that a revolutionary war would start. Where they are lacking there is little likelihood of a successful revolutionary war even starting.

In summary, the idea behind the book is promising, but the execution disappointing. There is obviously some hard military sense, and the discussions should stimulate some interesting ideas. But there is too much emotionalism and adoption of extreme positions to be of real worth to the serious student of warfare. The various contributions are not well co-ordinated, and there are too many irrelevancies, albeit interesting ones, to make a tight-knit well argued case. In his closing paragraph, even Elliott-Bateman admits that the over-all picture is rather blurred, but promises to sharpen things up in the next volume. □

THRACIAN PELTASTS AND THEIR INFLUENCE ON GREEK WARFARE, by J. G. P. Best. Groningen, Wolters-Noordhoff, 1969.

Reviewed by Dr T. B. Millar, Director, The Australian Institute of International Affairs.

THIS is a book for the specialist, and moreover for the specialist who reads ancient Greek. Peltasts were soldiers who carried a light shield (pelte) and a spear (or two javelins) — they were thus better able to protect themselves than the light-armed soldiers (who carried no shield), and were more mobile than the more heavily armed hoplites. The pelte, which was sometimes only made of wicker-work, was usually of a particular curved shape, and was specifically associated with Thrace, then a Greek colonial area at the north end of the Aegean Sea. This book deals with the use of Thracian peltasts in battles fought by the Greeks before, during and after the Peloponnesian War, i.e. the fifth and fourth centuries B.C. Not all peltasts were Thracians, and other armies at times copied their methods.

Mr Best is no Thucydides, and quotes extensively from him. But he writes interestingly, especially where he lets the narrative speak for itself and the Ph.D thesis (if such it was) does not intrude. We can probably conclude safely that he has examined every bit of available evidence on the location and use of peltasts at this time. For the soldier rather than the archaeologist, one could perhaps wish for a less literary and more military analysis. The majority of the mercenaries who fought in Spartan and Athenian armies in Greece were peltasts, and where employed in their proper role and tactics they were invaluable to Xenophon, Demosthenes, Iphikrates, and even later to Alexander and Phillip V. □

MONTHLY AWARD

The Board of Review has awarded the \$10 prize for the best original article published in the August 1970 issue of the journal to Major P. R. Phillips for his contribution 'The Camp of Tran Van Hoang'.